

CODE NUMBER

20201412

DESCRIPTION

ST-2029 Water Closet and SLOAN 8111 Flushometer.

COMPONENTS

- Flushometer: Code 3790071
- Water Closet: Code 2102029

DETAILS

- Flush Volume: 1.28 gpf (4.8 Lpf)
- Nominal Dimensions: 26 ¾" x 14" x 17" (679 x 356 x 432mm)

FLUSHOMETER FEATURES

- 1" I.P.S. Screwdriver Bak-Chek® Angle Stop with Vandal Resistant Stop Cap
- Vacuum Breaker with Flush Connection
- Spud Coupling and Spud Flange for 1½" Top Spud
- Sweat Solder Adapter with Cover Tube and Cast Wall Flange
- User friendly three (3) second Flush Delay
- Flex Tube Diaphragm designed for improved life and reduced maintenance
- No External Volume Adjustment to Ensure Water Conservation
- Stop Seat and Vacuum Breaker Molded from PERMEX® Rubber Compound for Chloramine resistance
- Infrared Sensor with Multiple-focused, Lobular Sensing Fields for high and low target detection
- Engineered Plastic Cover with replaceable Lens Window
- Courtesy Flush® Override Button
- Four (4) Size AA Batteries included

FIXTURE FEATURES

- White Vitreous China
- Elongated bowl
- Floor mounted, floor outlet
- Siphon jet flushing action achieves 1000g Map score when used with any Sloan flushometer
- Water spot area: 10⅞" x 9⅜" (26 cm x 24 cm)
- 1½" I.P.S. top spud inlet
- 2⅞" fully glazed trapway
- Closet bolts and caps included
- Toilet seat not included
- Static load rating of 1000 lbs. (See Notes)



COMPLIANCES & CERTIFICATIONS



(ADA Compliant, BAA Compliant, BREEAM Materials Credit, BREEAM Water Credit, EPD, Green Globes Materials & Resources Credit, Green Globes Water Credit, HPD, LEED Materials & Resources EPD Credit, LEED Materials & Resources HPD Credit, LEED V4 Water Efficiency Credit, Satisfies LEED Credits, WaterSense Listed)

DOWNLOADS

- [SS/ST/SU/WETS/WEUS Fixtures Repair and Maintenance Guide](#)
- [Additional Downloads](#)

NOTES

All information contained within this document subject to change without notice.

Static load tested according to the procedure outlined in Section 6.7 of ASME A112.19.2. Not recommended for bariatric use.

Sloan 10500 Seymour Ave, Franklin Park, IL 60131

Phone: 800.982.5839 • Fax: 800.447.8329 • sloan.com

ROUGH-IN

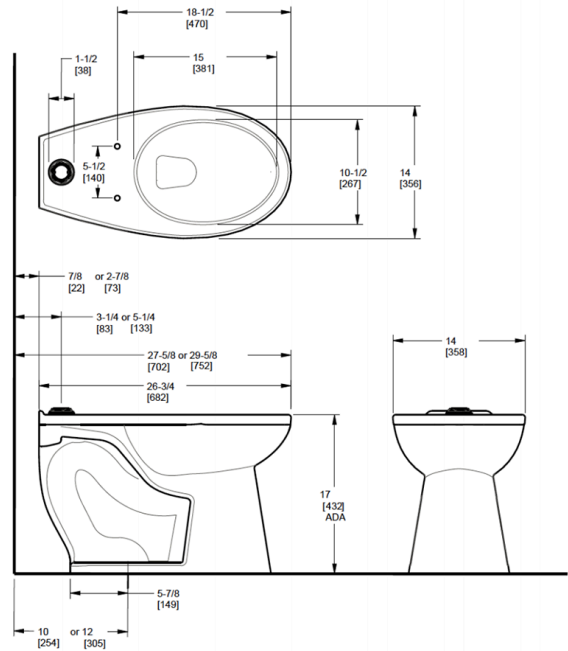
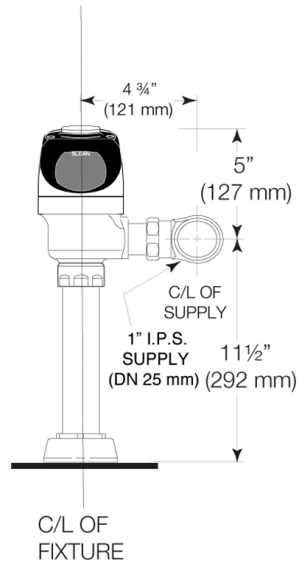
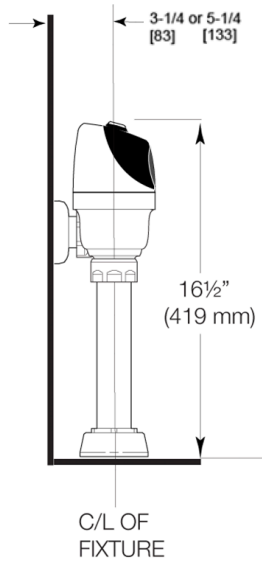

Sloan 10500 Seymour Ave, Franklin Park, IL 60131
Phone: 800.982.5839 • Fax: 800.447.8329 • sloan.com